

PERCENTAGE RECOVERY OF DIOXIN HOMOLOGUE THROUGH POWER-PREP ACCORDING TO THE ELUTING SOLVENTS AND THEIR AMOUNTS

Tae-Uk Jeong¹, Dong-Gyu Kim², Si-Weon Choi³, Dong-Cheol Seo⁵, Hong-Jae Lee⁴, Jong-Soo Heo⁵

¹Division of Applied Life Science, Gyeongsang National University and Busan Regional Office, National Veterinary Research & Quarantine Service

²Seoul Regional Office, National Veterinary Research and Quarantine Service

³Busan Regional Office, National Veterinary Research and Quarantine Service

⁴Department of Environmental Engineering, Jinju National University

⁵Division of Applied Life Science, Gyeongsang National University

Introduction

Because of the persistence and accumulation of polychlorinated dibenzo dioxins(PCDDs) and polychlorinated dibenzo furans(PCDFs) in the environment, dioxins contamination is regarded as a global issue. And various methods for analyzing PCDDs and PCDFs have been developed and improved. According to US EPA method, cleanup method was very various. Conventional cleanup methods are very dependable, but are time consuming and use large volumes of organic solvents. To increase the efficiency of cleanup for the analysis of PCDDs and PCDFs, we used high speed automated sample cleanup system for dioxins which is called Power-PrepTM(Fluid Management System Inc., USA). Power-PrepTM gave us swift analysis of dioxin and its precision and accuracy. This system was designed to cleanup of toxic compound such as dioxins, PCBs, pesticides and PAHs using silica, alumina and carbon column. Using this system, it is possible to conduct several samples in less than 1.5 hours, thereby, achieving high recoveries and excellent precision and accuracy for all dioxin congeners.

In this experiment, we carried out PCDDs and PCDFs analysis by FMS(Fluid Management System Inc.) with 3 eluting solvents such as toluene, hexane and dichloromethane to find out the best eluting solvent and its amounts.

Materials and Method

All standard solutions such as calibration standard, LCS, CSS and ISS used were obtained from Wellington Lab. Inc(USA).

Five-gram aliquots of corn oil as a lipid simulant were weighed into thimble within soxhlet extraction apparatus. And 200ul of LCS spiking solution(2-4ng/ml) was also spiked into thimble. Soxhlet extraction solvent was used 300ml of n-hexane : dichloromethane (1:1) for 18hrs according to the EPA method 1613. Sodium sulfate anhydrous for pesticide residue and PCB analysis by Kanto(Japan) was used to remove water. Silica gel 60 for column chromatography by Merck(Germany) was used as the adsorbent for extract cleanup. Silica gel was rinsed with dichloromethane and baked at 180 for overnight. Acidic silica gel was made of concentrated sulfuric acid and activated silica gel(30% W/W) and removed lipid from extracts. The other solvents used were ultra resi grade for organic residue analysis(J.T.Baker, USA). CSS(Cleanup Standard Spiking Solution, Wellington lab Inc.) was spiked just prior to cleanup of extracts. The cleanup procedure was performed by Power-Prep™(Fluid Management System Inc., USA) which was composed of silica, alumina and carbon column. The principle of Power-Prep™ was shown in Fig. 1.

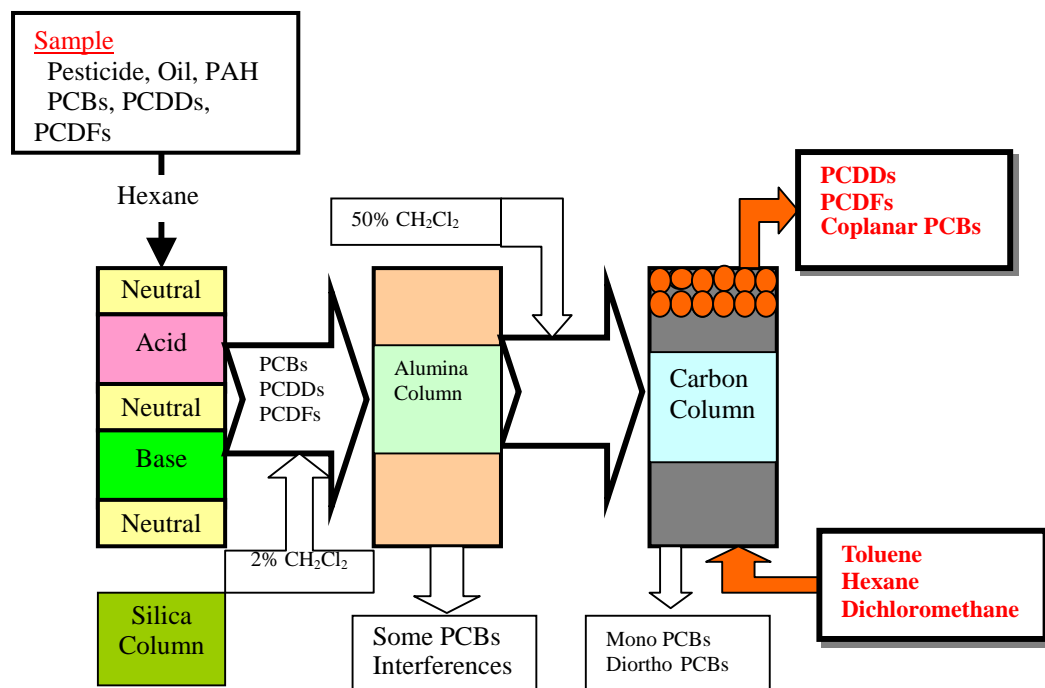

Fig. 1. The principle of Power-Prep™ cleanup unit used in all experiments.

Multi-layer silica column(11mm ID×177mm length) contains 4g of acidic silica(30% concentrated sulfuric acid), 2g of basic silica(23% 1.0N sodium hydroxide) and 1.5g of neutral silica(10% water). Alumina column(11mm ID×177mm length) contains 12.5g of basic alumina and carbon column(11mm ID×100mm length) contains 0.275g of 8% carbon on celite 545-AW. All columns were prepared in Teflon column and sealed. The whole system configuration is computer controlled and consists of power supply module, control module, pump & pressure module, valve drive module and sample processing module. The cleanup solvents were n-hexane, dichloromethane, ethylacetate, benzene. Toluene, n-hexane and dichloromethane were used as eluting solvents and received at an interval of 10ml to 100ml.

All eluting solvents were evaporated to dryness by rotary evaporator(Heidolph, Germany) and nitrogen flow equipment(Organomation Associates Inc., USA). The final volume was made up exactly 90ul with nonane. And then, added to 10ul of syringe standard(ISS ; Internal Standard Spiking Solution, Wellington lab Inc.).

Purified extracts were analyzed by HRGC/HRMS on HP 6890 series plus gas chromatograph(Agilent, USA) equipped with a CTC A200SE autosampler and coupled to an Autospec Ultima mass spectrometer(Micromass, UK), using a positive electron ionization source and operating in the selected ion monitoring mode at over 10,000 resolving power at 10% valley definition. Chromatographic separation was carried out with DB-5MS(J&W Scientific, USA) fused-silica capillary column(60m length×0.25mm ID×0.25um film thickness) with helium as carrier gas following procedures of EPA method 1613.

Results & Discussion

The recovery of homologue profiles of dioxin according to amount of the eluting solvent using Power-PrepTM which is automated sample cleanup system were presented in Table 1. and Fig. 2

In the case of toluene as eluting solvent, most dioxin homologues were eluted by about 64-94% in 10ml, and over 95% within 30ml. TCDF and PeCDF were eluted by about 85% in 10ml, and 6.8 and 8.4% in 10-20ml, respectively. HxCDF and HpCDF were eluted by 76.5 and 70.6% in 10ml. And those in 10ml were lower than those of the other homologues. TCDD was eluted by 93.8% in 10ml and not eluted after 30ml. The recovery of HxCDD in 0-10, 10-20 and 20-30ml was about 81, 16 and 4%, respectively. HpCDD in 0-10 and 10-20ml was eluted by 73.6 and 26.4%, respectively. OCDD in 10ml was eluted by 64% and its elution amount was low in comparison with the other homologues. Regardless of dioxin homologue, tetra- and penta- in 10ml was eluted over 85% and almost not eluted after 30ml. Hexa-, hepta and octa- in 10-20ml was eluted by 15-26%.

When we used the hexane and dichloromethane as eluting solvent in spite of the nonpolar solvent, all dioxin homologues were not eluted contrary to toluene.

Table 1. The recovery of homologue profiles of dioxin using Power-Prep™ with toluene as eluting solvent.

	0-10	10-20	20-30	30-40	40-50	50-100	Total
TCDF	66.2 (86.8)	5.2 (6.8)	2.5 (3.3)	0.0 (0.0)	2.4 (4.1)	0.0 (0.0)	76.3 (100)
PeCDF	81.3 (85.7)	8.0 (8.4)	2.4 (2.5)	0.0 (0.0)	1.4 (1.5)	1.8 (1.9)	94.9 (100)
HxCDF	49.1 (76.5)	11.3 (17.6)	2.7 (4.2)	1.1 (1.7)	0.0 (0.0)	0.0 (0.0)	64.2 (100)
HpCDF	45.6 (70.6)	13.5 (20.9)	2.9 (4.5)	1.6 (2.5)	0.0 (0.0)	1.0 (1.5)	64.6 (100)
TCDD	59.5 (93.8)	3.9 (6.2)	0.0 (0.0)	0.0 (0.0)	0.0 (0.0)	0.0 (0.0)	63.4 (100)
PeCDD	87.3 (84.9)	10.5 (10.2)	3.1 (3.0)	1.9 (1.8)	0.0 (0.0)	0.0 (0.0)	102.8 (100)
HxCDD	52.6 (80.7)	10.1 (15.5)	2.5 (3.8)	0.0 (0.0)	0.0 (0.0)	0.0 (0.0)	65.2 (100)
HpCDD	50.8 (73.6)	18.2 (26.4)	0.0 (0.0)	0.0 (0.0)	0.0 (0.0)	0.0 (0.0)	69.0 (100)
OCDD	41.1 (64.4)	16.2 (25.4)	4.3 (6.7)	0.0 (0.0)	0.0 (0.0)	2.2 (3.4)	63.8 (100)

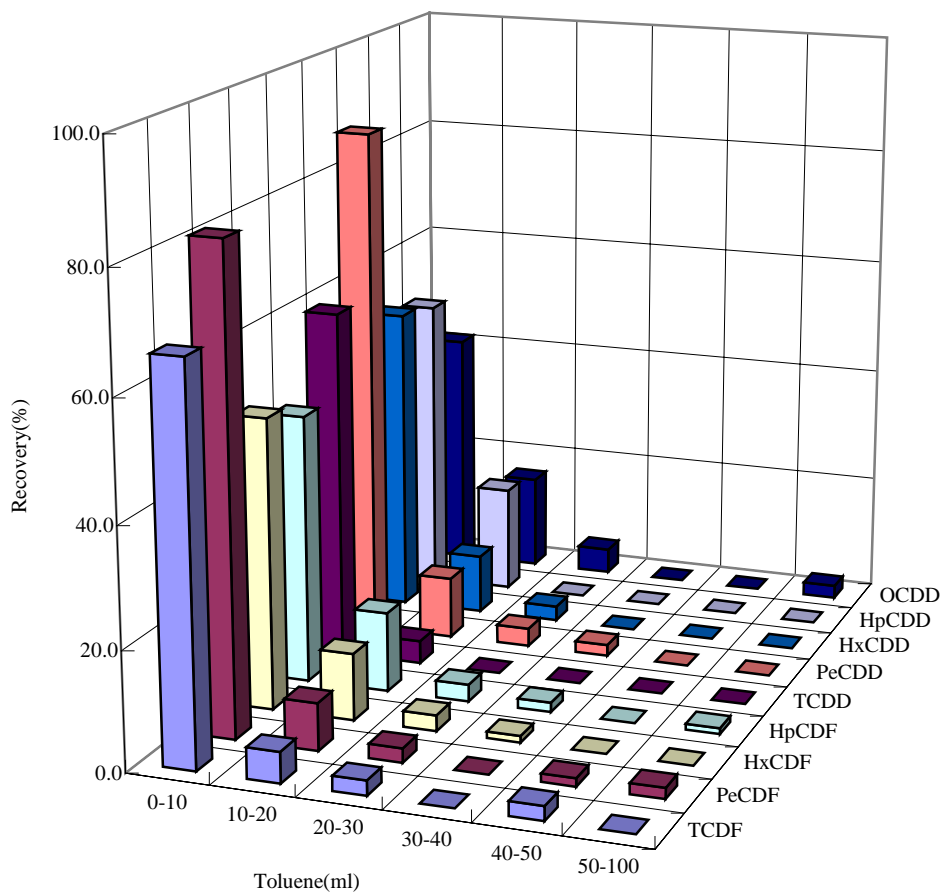

Fig. 2. The recovery of homologue profiles of dioxin according to amount of the eluting solvent.

Reference

1. US EPA method 1613 revision B (1994) Tetra-through octa-chlorinated dioxins and furans by isotope dilution HRGC/HRMS, Office of Water, Washington, D.C., USA
2. J.F.Focant, E.D.Pauw, (2002). J. of Chromatography B., 776 : 199-212.
3. R.Fisher, E.Aries, D.R.Anderson, N.Ordsmith, K.Hall, L.Fitzpatrick, F.Barclay., (2003). Rapid clean-up for determination of PCDD/Fs using a

multi-layer silica gel column connected to a dual-layer reversible carbon column. Organohalogen Compounds. 1